

# GNExL2 PA Loudspeaker 25W

**The flameproof GNExL2 PA loudspeaker is IECEx and ATEX approved, suitable for Zone 1 & Zone 2 applications. Rated power: 25W, available in 70V/100V line transformer and 8 & 16 Ohm low impedance versions.**

The GNEx range features enclosures manufactured from GRP (glass reinforced polyester), moulded in natural red, but also available in other colours.

The re-entrant flare horn is high impact, fire retardant ABS. All models contain dual cable entries, large termination areas containing in & out terminals and an ingress protection of IP66/67.

## Features

- Very large termination area.
- Ratchet adjustable stainless steel 'U' bracket.
- IN & OUT terminals

## Approvals

- ATEX certificate: SIRA 13ATEX1139X
- IECEx certificate: IECEx SIR 13.0029X
- Ex EAC TR CU 012/2011 certified: KZ.1510019.22.01.00271
- INMETRO IEx 20.0050X

## Coding

- II 2G Ex d IIC T4 Ta. -60° to +50°C
- II 2G Ex d IIC T3 Ta. -60° to +65°C
- II 2G Ex d IIB T6 Ta. -60° to +50°C
- II 2G Ex d IIB T5 Ta. -60° to +65°C



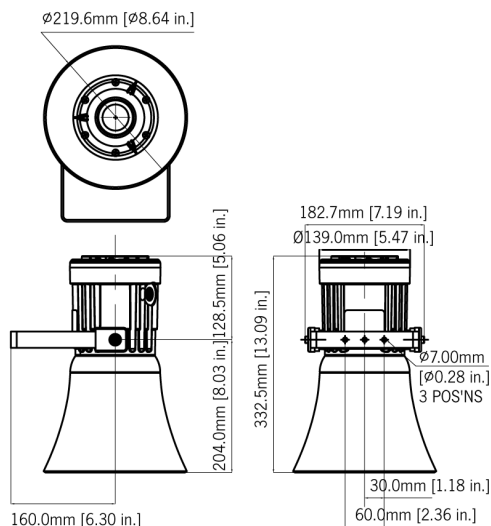

## Specification

SPL:	105dB +/-3dB @ 1w @ 1m (Pink) 119dB +/-3dB @ 25w @ 1m (Rated)
Rated power:	25 Watts RMS
70v line tapings:	25w / 12.5w / 6w / 2w tapings
100v line tapings:	25w / 12.5w / 6w / 2w tapings
Low impedance:	8 Ohm or 16 Ohm
Dispersion:	130° @ 1kHz & 32° @ 4kHz
Frequency range:	300Hz to 8000 Hz
DC Line monitoring:	2.2 $\mu$ F Capacitor (Transformer version) 470 $\mu$ F Capacitor (Impedance version)
Ingress protection:	IP66/67
Enclosure material:	GRP
Colour:	RAL3000 Red (others available on request)
Horn flare:	High impact UL94 V0 & 5VA FR ABS (Red)
Cable entries:	Dual M20 ISO
Terminals:	0.5 to 4.0mm <sup>2</sup> cables
Relative humidity:	95% - Additional tropicalisation is recommended for applications where both high relative humidity and high ambient temperatures exist
Weight:	70/100V line: 4.3kg/9.46lbs Low imp.: 3.95kg/8.59lbs

## Part Codes

Version:	Part code:	Description:
Product type:	GNExL2	25W Loudspeaker
Type:	V100 R008 R016	100V/70V Line Transformer 8 Ohm Low impedance 16 Ohm Low impedance
Cable Entry Type: [e]	A B C D E F G	2 x M20x1.5mm 2 x 1/2" NPT - adaptors 2 x 3/4" NPT - adaptors 2 x M25x1.5mm - adaptors 1 x 1/2" NPT - adaptor 1 x 3/4" NPT - adaptor 1 x M25x1.5mm - adaptor
Stopping plug material: [m]	B N S	Brass Nickel Plated Stainless Steel
Bracket material & tag: [s]	1 2 3 4	A2 304 Stainless Steel A4 316 Stainless Steel A2 304 St/St with Equip. Tag A4 316 St/St with Equip. Tag
Product version: [v]	A1	Approval to ATEX & IECEx (default)
Enclosure colour: [x]	R S	Red Special colour - contact sales
Accessories:	SP65-0001-A2 SP65-0001-A4 SP65-0003-A2 SP65-0003-A4	Pole Mount Bracket Kit 2" St/St A2 (304) Pole Mount Bracket Kit 2" St/St A4 (316) Sunshade - St/St A2 (304) Sunshade - St/St A4 (316)